

FITTING INSTRUCTIONS

making everyday smoother

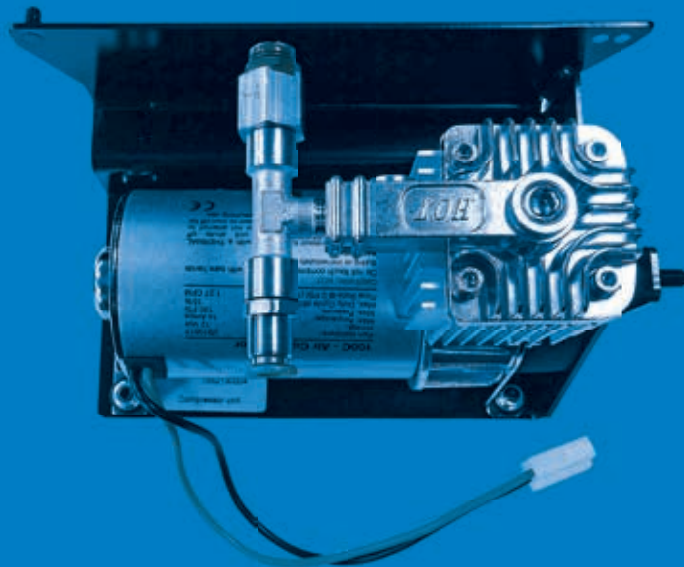

MERCEDES BENZ SPRINTER VS30

***VB-SemiAir Comfort set (Camper)
rear axle***

**FOR KIT: 1555370234, 1555370235, VBSA-MBS-35-OXC-L/R,
VBSA-MBS-50-OXC-L/R, VBSA-MBS-FWD-OXC-L/R**



REVISION TABLE

Document number	730155022700		
New revision:	V1.2	Old revision:	V1.1
Release date (yyyy-mm-dd):	2024-03-28		
Page (new):	Changes:		
6	Updated: photos		
14, 16	Updated: photos step 3 and 7		
18, 20	Updated: photos step 11 and 13		
1	Added: kit numbers		

© 2024, VB-Airsuspension B.V.

EN All rights reserved. No part of this publication may be reproduced, stored in a retrieval system, or transmitted in any form or by any means, electronic, mechanical, photocopying, recording or otherwise, without the publisher's prior consent. That does also count for the schemes and drawings.

NL Alle rechten voorbehouden. Niets uit deze uitgaven mag worden verveelvoudigd en/of openbaar gemaakt worden door middel van druk, fotokopie, microfilm of op welke andere wijze dan ook, zonder voorafgaande schriftelijke toestemming van VB-Airsuspension B.V. Dit geldt ook voor de bijbehorende tekeningen en schema's.

DE Alle Rechte vorbehalten. Vervielfältigung und/oder Veröffentlichung durch Nachdruck, Fotokopie, Mikrofilm oder auf jede andere Art – auch auszugsweise – ohne vorherige schriftliche Genehmigung von VB Airsuspension ist nicht zulässig. Dies gilt auch für die zugehörigen Zeichnungen und Pläne.

FR Reproduction interdite. Toute reproduction, tout enregistrement dans une base de données ou toute transmission sous toute forme ou par tout moyen : électronique, mécanique, photocopie, enregistrement ou autre, de tout ou partie de cette publication, est formellement interdit(e) sans l'autorisation préalable de VB-Airsuspension B.V. Ceci est aussi valable pour les dessins et les schémas.

TR Tüm hakları saklıdır. Bu yayının hiçbir bölümü herhangi bir yolla, elektronik olarak, mekanik olarak, fotokopiyle, kayıtlı veya başka bir şekilde, VB-Airsuspension B.V.'nin önceden verilmiş yazılı izni olmaksızın kopyalanamaz, bir erişim sisteminde saklanmaz veya iletilemez. Bu hüküm, ilgili çizim ve şemalar için de geçerlidir.

IT Tutti i diritti riservati. Nessuna parte di questa pubblicazione può essere riprodotta, archiviata in un sistema di recupero o trasmessa in qualsiasi forma o con qualsiasi mezzo, elettronico, meccanico, fotocopia, registrazione o altro, senza il previo consenso dell'editore. Questo vale anche per gli schemi e i disegni.

TABLE OF CONTENTS

1. Vehicle	4
2. Fitting time	4
3. Symbols	4
4. Colour marking	4
5. Parts	5
6. Variations	6
7. Fitting instructions	7
8. Installation	13
8. Checklist	32

EN



Attention:

Please check, before mounting / disassemble, the workshop manual of the manufacturer. When in doubt always follow the instructions of the manufacturer! See the workshop manual for the correct tightening torque!

NL



Belangrijk:

Controleer voor het monteren / demonteren de werkplaatshandleiding van de fabrikant. Bij twijfel volg altijd de werkwijze van de fabrikant van het voertuig! Zie de werkplaatshandleiding voor het juiste aanhaalmoment!

DE



Achtung:

Kontrollieren Sie vor der Montage / Demontage zuerst die Werkstattanleitung des Fahrzeugherstellers! Befolgen Sie im Zweifel immer die Anweisungen vom Fahrzeugherstellers! Das richtige Anzugsdrehmoment finden Sie im Werkstatthandbuch!

FR



Attention:

Avant de commencer le montage / démontage vérifier le manuel d'atelier du fabricant. En cas de doute, suivez toujours les préconisations du constructeur du véhicule! Voir le manuel d'atelier du fabricant pour le couple de serrage correct!

TR



Önemli:

Kurulum/sökme için üreticinin servis kılavuzunu kontrol edin. Şüpheleriniz olursa her zaman araç üreticisinin talimatlarını izleyin. sıkma torku için araç üreticisinin yönergelerini izleyin!

IT



Attention:

Si prega di controllare, prima di montare/smontare, il manuale d'officina del produttore. In caso di dubbio seguire sempre le istruzioni del produttore! Consultare il manuale d'officina per la coppia di serraggio corretta!



1. VEHICLE

Make	Trade name	Year
Mercedes-Benz	VS30	>2018

2. FITTING TIME



Watch out!

3. SYMBOLS

EN	Tightening / loosen	Tightening with torque	Tighten hand-tight	Reuse	See workshop manual	Ok / Not OK	Left	Right	Left and right
NL	Aandraaien / losdraaien	Aandraaien met moment	Handvast aandraaien	Hergebruiken	Zie werkplaats-handleiding	Ok / niet Ok	Links	Rechts	Links en rechts
DE	Anziehen / lockern	Anziehen mit Anzugsdrehmoment	Handfest anziehen	Wiederverwenden	Siehe Werkstattanleitung	In Ordnung / Nicht in Ordnung	Links	Rechts	Links und rechts
FR	Serrer / relâcher	Couple de serrage	Serrer / relâcher	Réutiliser	Voir le manuel d'atelier	Ok / Mauvais	Gauche	Droite	Gauche et droite
TR	Anahtar ile sıkın	Torkmetre ile sıkın	Elle sıkın	Yeniden kullanımı	Servis kılavuzunu inceleyin	Uygun / Uygun değil	Sol	Sağ	Sol ve sağ
IT	Serraggio / allentare	Serraggio con coppia	Stringere a mano	Riutilizzare	Consultare il manuale d'officina	Ok / Non OK	Sinistra	Destro	Sinistra e destra

4. COLOUR MARKING

Color	Description
Green	Left rear
Black	Right rear
Groen	Links achter
Zwart	Rechts achter
Grün	Links hinten
Schwarz	Rechts hinten
Vert	Arrière gauche
Noir	Arrière droit

Color	Description
Yeşil	Sol arka
Siyah	Sağ arka
Verde	Posteriore Sinistro
Nero	Posteriore Destro

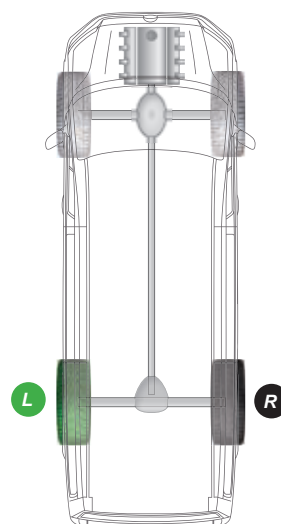

5. PARTS

#	Quantity	Item number	Description
1	1	1555370138	Control panel Right hand
	1	1555370139	Control panel Left hand
2	1	1552130004	Compressor unit
3	1	1552200001	Wiring harness
-	1	1552300032	Fasteners
-	1	1552250027	Air tube set

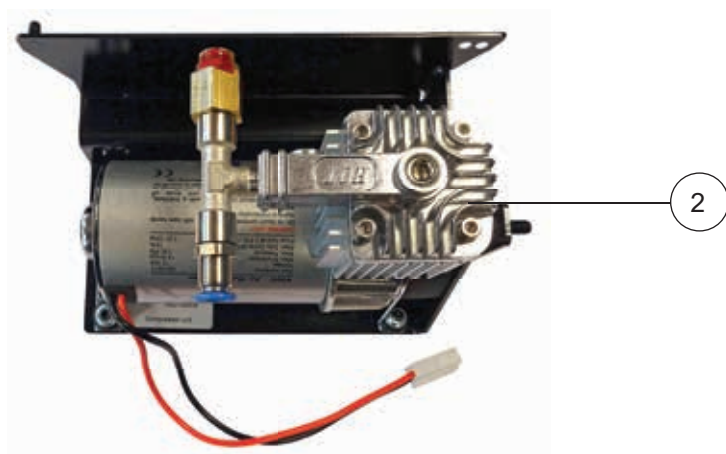
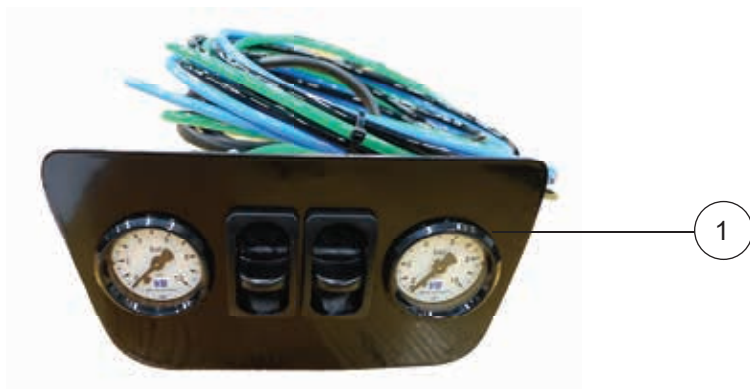

6. VARIATIONS

A Kit number 1555370234 (Right hand)



B Kit number 1555370235 (Left hand)



This manual has been put together with great care and describes the steps for installing the air suspension indicated on the front page. However, the content of this manual is a snapshot view of the situation as at the time it was written.

Your vehicle may differ from the vehicles shown in the photographs. In some cases, it may not be possible to fit specific parts in the position indicated. In this case, you are advised to identify an alternative position for the parts yourself. A condition for an alternative position is that the compressor and the parts from the control panel must remain within the dimensions of the interior (these parts must remain dry at all times).

VB-Airsuspension reserves the right to introduce technical changes at any time without warning.

VB-Airsuspension is not liable for any damage resulting from not following these fitting instructions.

- Consult with the customer as to where they want the inflation valves fitted.
- Use vehicle workshop manuals where necessary.
- Always follow the vehicle manufacturer's conversion instructions, unless expressly stated otherwise in this manual.
- Always tighten nuts and bolts to the specified torque.
- If modifications have been made to the original anti-corrosion system, this must be rectified immediately. Use spray wax or a protective coating for this purpose.
- Always refit removed tubes and wires in the same way they were originally fitted.
- Secure pipes and wires with a sufficient number of tie-wraps. Ensure that the wires cannot be placed under tension.
- The supply cable must be at least 100 mm away from the ABS/ESP block, the sensors and other control equipment.
- Wires must not be routed above or across the battery.
- Ensure that there are no tight bends in air tubes and that they cannot be kinked or chafe against other parts.
- Never attach air tubes, wires or other parts to the vehicle's brake lines.
- Fit the air tubes in accordance with the colour code system used by VB-Airsuspension.
- Do not leave any tools, cleaning cloths or other materials behind after completing work.
- Check the system for air tightness after fitting.
- Check that the air springs always have at least a 1 cm all-round clearance at maximum pressure ($P_{max} = 3.5 \text{ bar}$).
- Take the vehicle for a test drive after fitting.

NL 7. MONTAGEVOORSCHRIFTEN

Deze handleiding is met veel zorg opgesteld en beschrijft werkzaamheden voor de op het voorblad vermelde luchtvering. Het samenstellen van deze handleiding is echter een momentopname van de stand van zaken op het moment van schrijven.

Het kan voor komen dat uw voertuig afwijkt van de afbeeldingen. Daarnaast kan het voor komen dat onderdelen niet op de aangegeven positie gemonteerd kunnen worden. In dit geval raden wij u aan om zelf een alternatieve positie voor de onderdelen te vinden. Voorwaarde voor een alternatieve positie is dat de compressor en de onderdelen uit het bedieningspaneel binnen de afmetingen van het interieur moeten blijven (deze onderdelen dienen ten alle tijden droog te blijven).

VB-Airsuspension behoudt zich het recht voor om te allen tijde zonder voorafgaande waarschuwing technische aanpassingen door te voeren.

VB-Airsuspension kan niet aansprakelijk worden gehouden voor schade voortvloeiende uit het niet monteren conform deze montagehandleiding.

- Overleg met de klant waar hij/zij de vulventielen gemonteerd wil hebben.
- Maak indien nodig gebruik van de voertuigwerkplaatshandleidingen.
- Volg te allen tijde de ombouwvoorschriften van de voertuigfabrikant op, tenzij in deze handleiding nadrukkelijk anders vermeld staat.
- Zet bouten en moeren altijd met het voorgeschreven aanhaalmoment vast.
- Als er aanpassingen aan het originele anticorrosiesysteem zijn aangebracht, dient dit meteen hersteld te worden. Gebruik hiervoor bijvoorbeeld spraywax of beschermcoating.
- Zet losgenomen leidingen en kabels altijd op de oorspronkelijke manier vast.
- Leg de kabels en leidingen met voldoende kabelbinders vast. Zorg ervoor dat de kabels niet op trek belast kunnen worden.
- De voedingskabel moet minimaal 100 mm van het ABS/ESP-blok, de sensoren en andere stuurapparaten lopen.
- De kabels mogen niet op of over de accu heen gelegd worden.
- Vermijd dat luchtleidingen in een scherpe bocht komen te liggen, kunnen knikken of langs andere delen kunnen schuren.
- Er mogen in géén geval luchtleidingen, kabels of andere onderdelen aan de remleidingen van het voertuig worden bevestigd.
- Monteer de luchtleidingen conform de kleurcodering gehanteerd door VB-Airsuspension.
- Zorg ervoor dat er geen gereedschappen, poetslappen of andere materialen achterblijven.
- Controleer het systeem na de montage op luchtdichtheid.
- Controleer altijd of de balgen bij maximale druk ($P_{max} = 3,5$ bar), rondom een vrije ruimte hebben van minimaal 1 cm.
- Maak na de montage een proefrit.

Diese Anleitung wurde mit Sorgfalt verfasst und beschreibt die Arbeitsschritte für die auf dem Deckblatt angegebene Luftfederung. Diese Anleitung stellt eine Momentaufnahme des aktuellen Stands zum Zeitpunkt des Verfassens der Anleitung dar.

Möglicherweise weicht Ihr Fahrzeugmodell von den abgebildeten Fahrzeugen ab. In einigen Fällen können bestimmte Bauteile nicht an der angegebenen Einbauposition montiert werden. Bestimmen Sie in diesem Fall bitte selbst eine geeignete Einbauposition für die Bauteile. Bedingung für die alternative Position ist, dass die Komponenten im Innenraum des Fahrzeugs montiert werden. Es ist wichtig, dass diese Teile nicht feucht werden.

VB-Airsuspension behält sich das Recht vor, jederzeit und ohne vorherige Ankündigung technische Änderungen vorzunehmen.

VB-Airsuspension kann nicht für Schäden haftbar gemacht werden, die aus Einbauten hervorgehen, die nicht gemäß dieser Montageanleitung durchgeführt wurden.

- Besprechen Sie mit dem Kunden, wo die Füllventile montiert werden sollen.
- Schlagen Sie ggf. in den Fahrzeugwerkstattanleitungen nach.
- Befolgen Sie stets die Umbauvorschriften des Fahrzeugherstellers, sofern in dieser Anleitung nicht ausdrücklich anders angegeben.
- Ziehen Sie Schrauben und Muttern stets mit dem vorgeschriebenen Anzugsdrehmoment fest.
- Wurden Anpassungen am Original-Anti-Korrosionssystem vorgenommen, müssen diese unverzüglich behoben werden. Verwenden Sie hierfür beispielsweise Sprühwachs oder Schutzbelag.
- Befestigen Sie gelöste Leitungen und Kabel stets auf die ursprüngliche Befestigungsart.
- Befestigen Sie die Kabel und Leitungen mit entsprechenden Kabelbindern. Die Kabel dürfen nicht auf Zug belastet werden.
- Das Speisekabel muss in mindestens 100 mm Abstand vom ABS/ESP-Block, den Sensoren und anderen Steuergeräten verlaufen.
- Die Kabel dürfen nicht auf oder über die Batterie geführt werden.
- Die Luftleitungen dürfen nicht stark gebogen oder geknickt werden bzw. dürfen nicht an anderen Teilen scheuern.
- Luftleitungen, Kabel oder andere Bauteile dürfen keinesfalls an der Bremsleitung des Fahrzeugs befestigt werden.
- Montieren Sie die Luftleitungen der von VB-Airsuspension festgelegten Farbkennzeichnung.
- Achten Sie darauf, dass keine Werkzeuge, Putztücher oder anderen Materialien zurückbleiben.
- Prüfen Sie das System nach dem Einbau auf Luftdichtigkeit.
- Prüfen Sie stets, ob bei maximalem Druck ($P_{max} = 3,5 \text{ Bar}$) um die Luftbälge ein Spiel von mindestens 1 cm vorliegt.
- Führen Sie nach dem Einbau eine Testfahrt durch.

FR 7. INSTRUCTIONS DE MONTAGE

Ce manuel a été élaboré avec le plus grand soin et décrit la procédure de montage de la suspension pneumatique mentionnée en couverture. Le contenu de ce manuel constitue toutefois un relevé actuel de la situation au moment de sa rédaction.

Il se peut donc que votre véhicule diffère des véhicules représentés sur les illustrations. Dans certains cas, il n'est pas possible de monter certaines pièces à l'endroit indiqué. Le cas échéant, nous vous conseillons de choisir vous-même une autre position de montage des éléments. Une condition pour une position alternative est que le compresseur et les pièces du panneau de commande doivent rester dans les dimensions de l'intérieur (ces pièces doivent rester sèches à tout moment).

VB-Airsuspension se réserve le droit à tout moment et sans préavis d'apporter des modifications techniques.

VB-Airsuspension décline toute responsabilité pour tout dommage découlant du montage non-conforme à ce manuel.

- Concertez-vous avec le client pour définir l'endroit où il souhaite faire monter les valves.
- Utilisez si nécessaire les manuels d'atelier du véhicule.
- Suivez scrupuleusement les consignes de transformation du constructeur du véhicule, sauf dispositions contraires explicitement indiquées dans le présent manuel.
- Serrez toujours les boulons et les écrous au couple de serrage prescrit.
- Si des adaptations ont été apportées au système anticorrosion d'origine, ceci doit être réparé immédiatement. Pour ce faire, utilisez par exemple de la cire en aérosol ou un revêtement protecteur.
- Resserrez toujours les conduites et les fils détachés comme ils l'étaient à l'origine.
- Attachez les câbles et les conduites avec des colliers rilsan en nombre suffisant. Veillez à ce que les fils ne puissent pas être sollicités en traction.
- Le câble d'alimentation doit passer à au moins 100 mm du bloc ABS/ESP, des capteurs et des autres dispositifs de commande.
- Les câbles ne doivent pas passer sur ou au-dessus de la batterie.
- Les conduites d'air doivent être disposées de manière à ne pas être coudées trop fortement, à ne pas pouvoir se plier et à ne pas pouvoir frotter contre d'autres éléments.
- Il ne faut en aucun cas fixer des conduites d'air, des fils ou d'autres éléments aux tuyaux de frein du véhicule.
- Montez les conduites d'air conformément au code de couleurs appliqué par VB-Airsuspension.
- Veillez à ne pas laisser des outillages, des chiffons ou d'autres matériels dans le véhicule.
- Après le montage, contrôlez l'étanchéité à l'air du système.
- Assurez-vous toujours que les coussins d'air conservent un jeu d'au moins 1 cm sur toute leur périphérie lorsqu'ils sont gonflés à pression maximale ($P_{max} = 3,5 \text{ bar}$).
- Après le montage, effectuez un parcours d'essai.

Bu kılavuz, büyük özen gösterilerek hazırlanmıştır ve ön sayfada gösterilen havalı süspansiyonun kurulumuna yönelik adımları açıklamaktadır. Ancak bu kılavuzun içeriği, durumun kılavuzun yazıldığı andaki genel bir görünümüdür.

Aracınız fotoğrafta gösterilen araçlar ile uyuşmayabilir. Bazı parçalar belirtilen konuma takılamayabilir. Bu gibi durumlarda, bu parçalar için alternatif bir konum belirlemeniz önerilir. Alternatif bir pozisyon için şart, kompresörün ve kontrol panelindeki parçaların, iç boyutlarda kalması gerektirir (bu parçalar her zaman kuru kalmalıdır).

VB-Airsuspension, herhangi bir uyarıda bulunmadan istediği zaman teknik değişiklik yapma hakkını saklı tutar.

VB-Airsuspension, bu montaj yönergeleri sonucu ortaya çıkan hasarlardan sorumlu değildir.

- Müşteriye, şişirme valfinin nereye monte edilmesini istediğini sorun.
- Gerektiğinde araç servis kılavuzlarını kullanın.
- Bu kılavuzda aksi açıkça belirtilmedikçe her zaman araç üreticisinin dönüştürme yönergelerini izleyin.
- Çalışma alanını temiz ve düzenli tutun.
- Somun ve civataları her zaman belirtilen tork ile sıkın.
- Orijinal korozyon önleyici sistemde modifikasyon yapılırsa, bu hemen düzeltilmelidir. Bu amaçla sprey cila veya koruyucu bir kaplama kullanın.
- Çıkarılan lastik ve kabloları her zaman orijinal montaj şekline göre yeniden takın.
- Boruları ve kabloları yeterli sayıda kayışla sabitleyin. Kabloların gerilime maruz kalmayacak konumda olduğundan emin olun.
- Besleme kablosu, ABS/ESP bloğundan, sensörlerden ve diğer kontrol ekipmanından en az 100 mm uzakta olmalıdır.
- Kablolar akünün üzerinden veya yanından geçirilmemelidir.
- İç lastiklerde sıkı bükülmeler olmadığından ve iç lastiklerin dolaşamayacak veya diğer parçalara sürtünerek aşınamayacak konumda olduğundan emin olun.
- İç lastikleri, kabloları veya diğer parçaları asla aracın fren hatlarına takmayın.
- İç lastikleri, VB-Airsuspension tarafından kullanılan renk kodu sistemine göre takın.
- Asla herhangi bir aleti, temizlik bezini veya diğer malzemeleri ortalıkta bırakmayın.
- Montajın ardından sistemi hava sızdırmazlığı açısından kontrol edin.
- Maksimum basınç (maks b. = 3,5 bar) durumunda, havalı yayların her tarafından en az 1 cm boşluk olduğundan emin olun.
- Montajın ardından aracı test sürüşüne çıkarın.

IT 7. ISTRUZIONI DI MONTAGGIO

Questo manuale è stato redatto con grande cura e contiene una descrizione di tutti i passaggi necessari per l'installazione delle sospensioni pneumatiche come indicato nel frontespizio. Il contenuto di questo manuale fornisce un quadro della situazione al momento della sua stesura.

VB-Airsuspension si riserva il diritto di apportare modifiche tecniche in qualsiasi momento senza preavviso.

Il veicolo può essere diverso da quello illustrato nelle istruzioni di montaggio. In alcuni casi, potrebbe non essere possibile montare parti specifiche nella posizione indicata. In questo caso, si consiglia di identificare personalmente una posizione alternativa per le parti. Una condizione per una posizione alternativa è che il compressore e le parti del pannello di controllo devono rimanere entro le dimensioni dell'interno (queste parti devono rimanere sempre asciutte).

VB-Airsuspension non si assume alcuna responsabilità per eventuali danni derivanti dal mancato rispetto delle presenti istruzioni di montaggio.

- Consultare il cliente dove desidera installare le valvole di riempimento.
- Se necessario utilizzare i manuali d'officina relativi al veicolo.
- Il kit di sospensioni pneumatiche è fornito per quattro angoli. Se un componente è progettato per un angolo specifico, sarà identificato con un'etichetta adesiva colorata. Montare le tubazioni pneumatiche conformemente al sistema di colori distintivi utilizzato da VB-Airsuspension.
- Seguire sempre le istruzioni di conversione del costruttore del veicolo, salvo il presente manuale non indichi diversamente.
- Contrassegnare i componenti rimossi per garantire che vengano rimontati nel veicolo giusto.
- Tutti i componenti rimossi e reinstallati devono essere controllati per garantire il loro corretto funzionamento.
- Serrare sempre i dadi e le viti forniti alla coppia di serraggio specificata, salvo diversamente indicato nel presente manuale. In tal caso attenersi alle direttive del costruttore del veicolo.
- Contrassegnare il fissaggio con bulloni con un marcatore a vernice di sicurezza.
- Eventuali modifiche al sistema anticorrosione originale devono essere immediatamente corrette. A questo scopo utilizzare cera spray o un rivestimento protettivo.
- Rimontare sempre i tubi e i cavi rimossi esattamente come erano montati in origine.
- Fissare tubi e cavi con un numero sufficiente di fascette serracavi. Accertarsi che i cavi non possano essere messi in tensione.
- Assicurarsi che le tubazioni pneumatiche non presentino pieghe strette e che non possano attorcigliarsi o sfregare contro altri componenti.
- Se necessario, mettere una guaina proteggi cavo alle tubazioni pneumatiche.
- Non collegare mai tubazioni pneumatiche, cavi o altri componenti alle tubazioni del freno del veicolo.
- Il cavo di alimentazione deve distare almeno 100 mm dal blocco ABS/ESP, dai sensori e dalle altre apparecchiature di controllo.
- I cavi non devono essere posati sopra la batteria o al suo interno.
- Una volta terminato il lavoro, non lasciare sul posto attrezzi, panni usati per la pulizia o altro materiale.
- Dopo il montaggio, verificare l'ermeticità del sistema.
- Controllare che attorno ai soffietti pneumatici sia sempre presente uno spazio di almeno 10 mm alla pressione massima.
- Dopo il montaggio, controllare le sospensioni pneumatiche rispetto alla lista di controllo.
- Dopo il montaggio, fare un giro di prova con il veicolo.

8. FITTING INSTRUCTIONS

A B

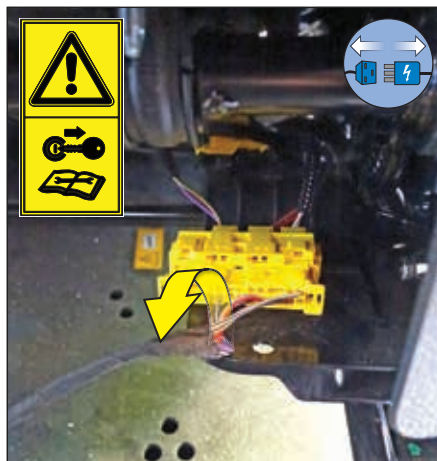
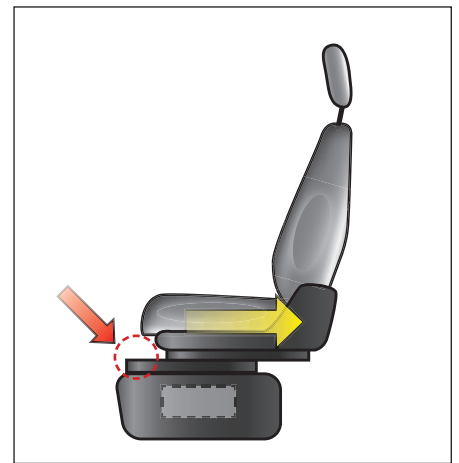
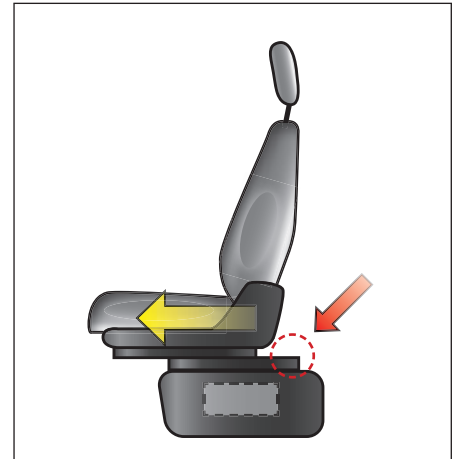

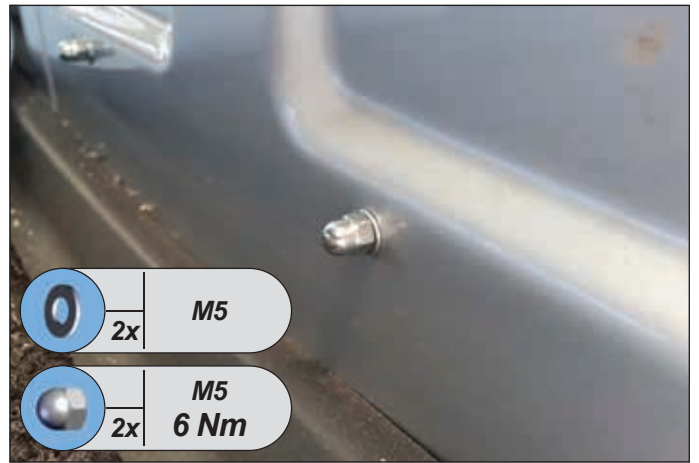
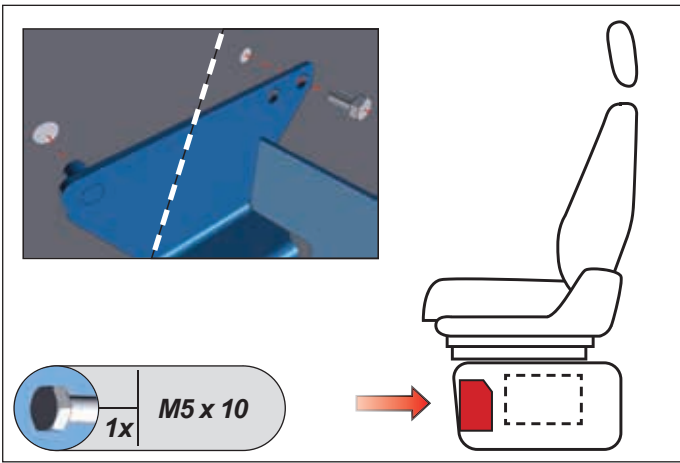
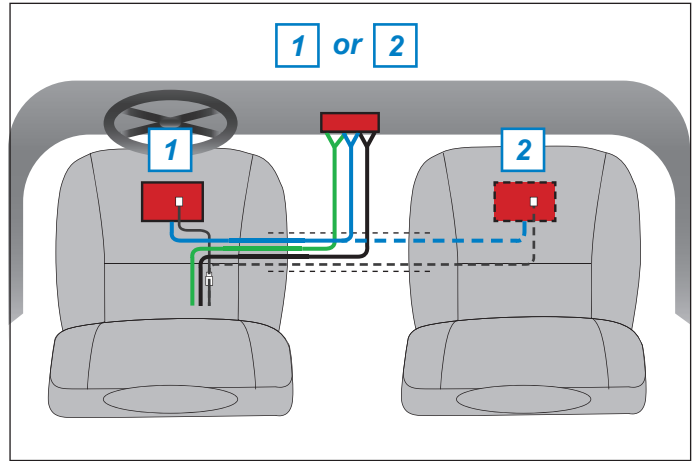
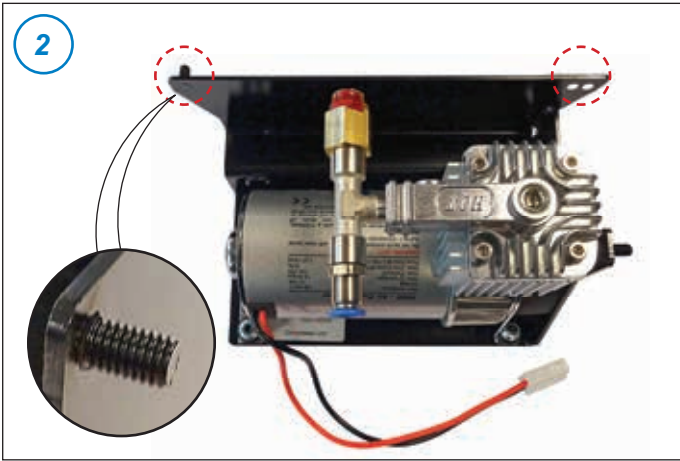

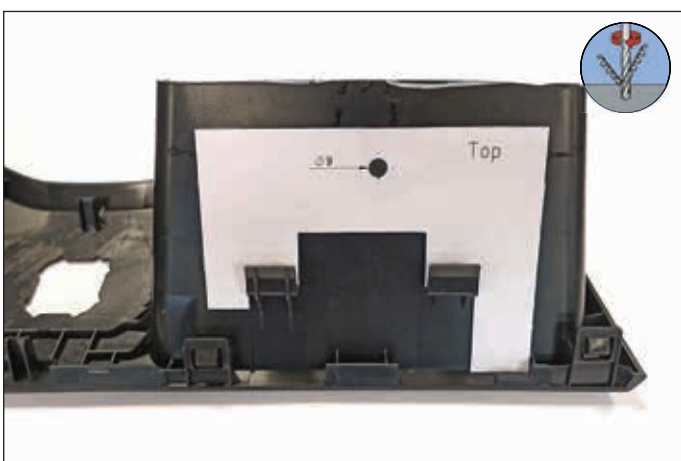
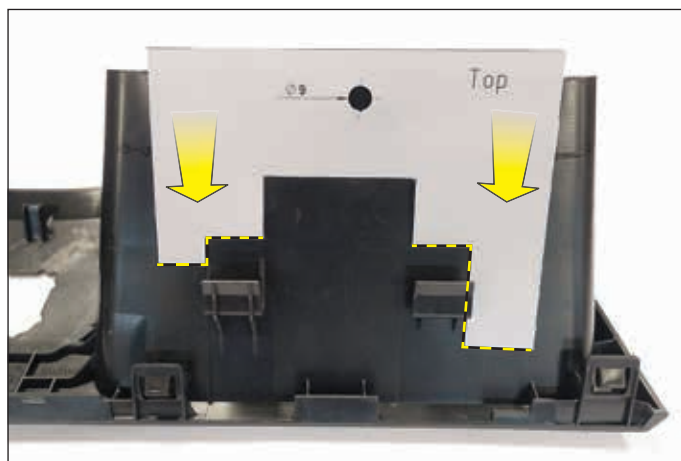
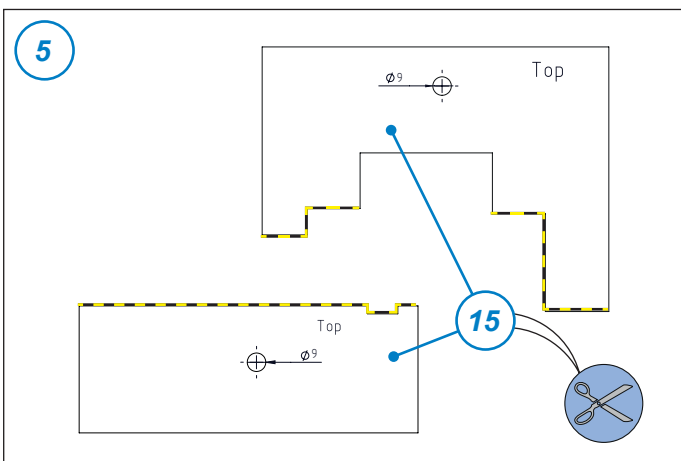
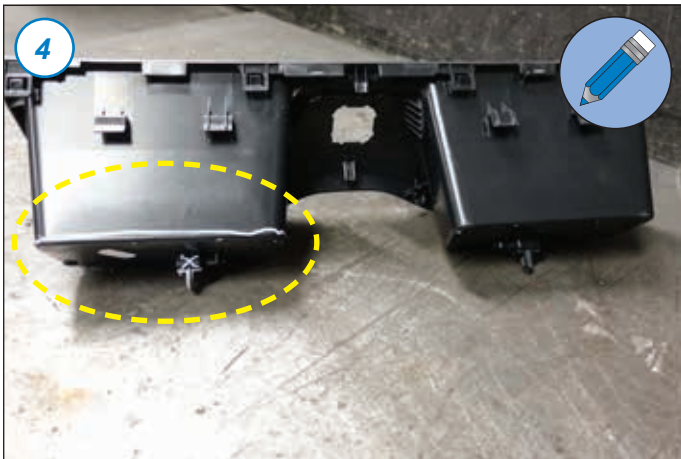

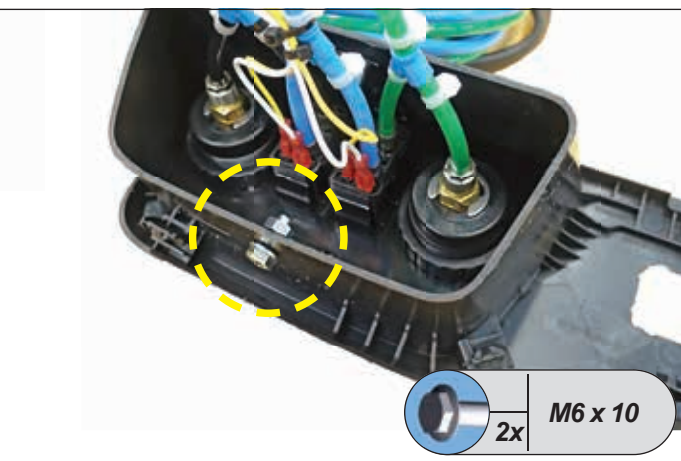
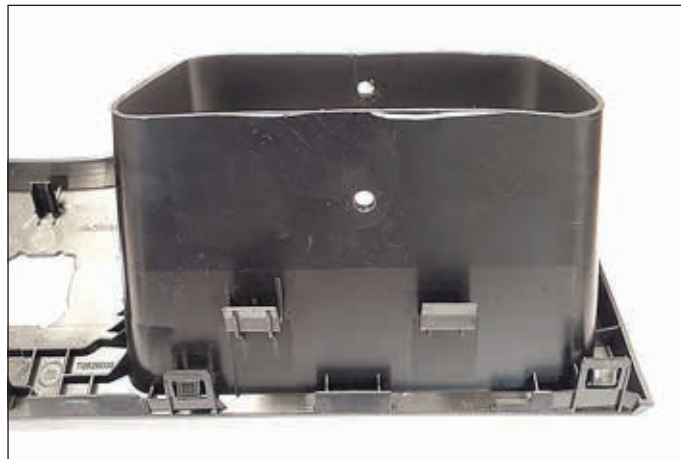

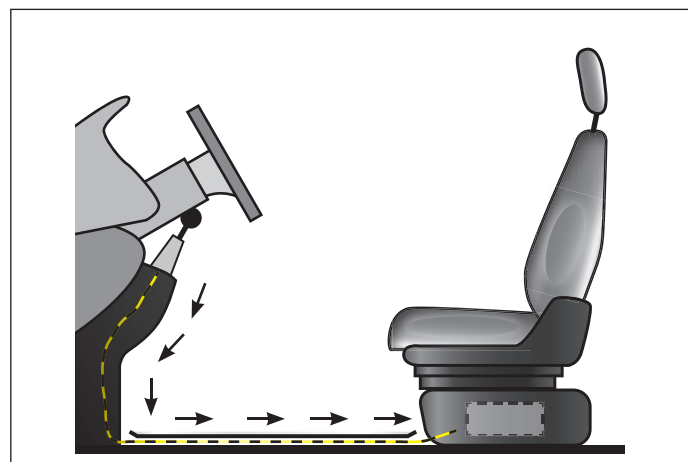
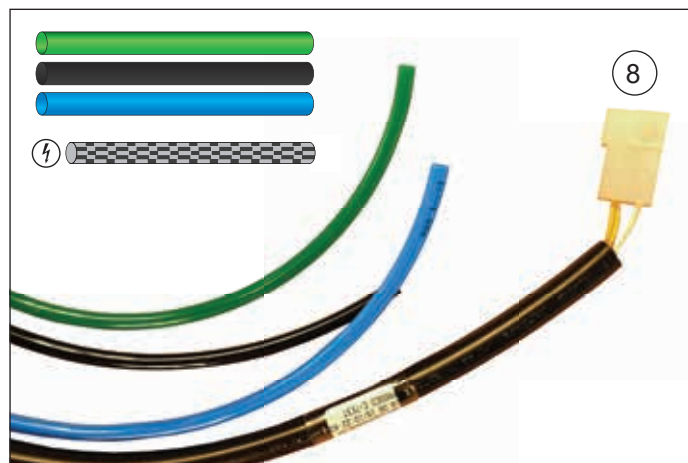

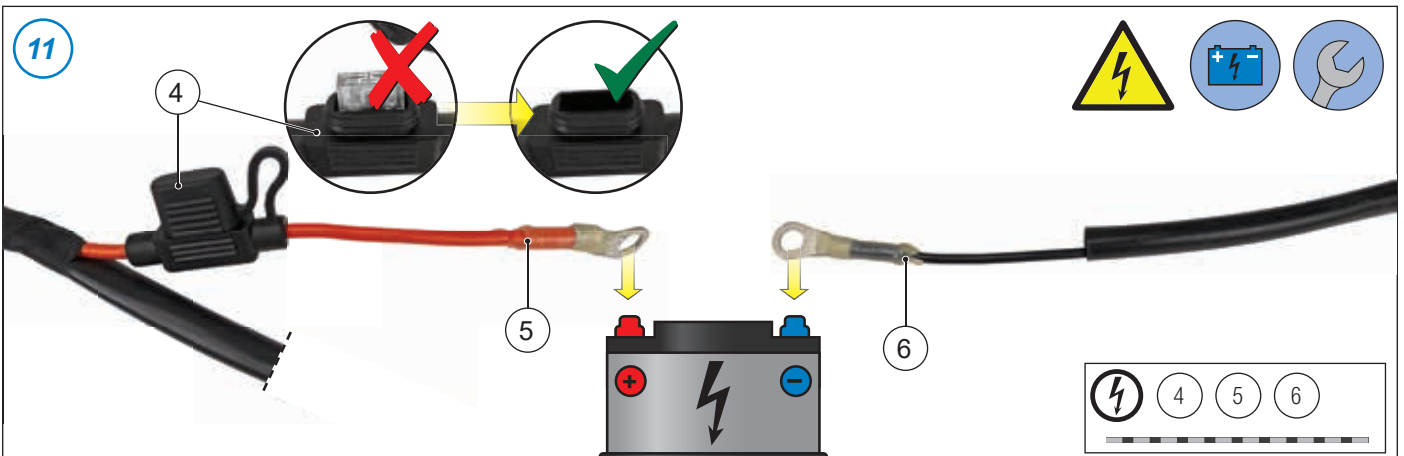
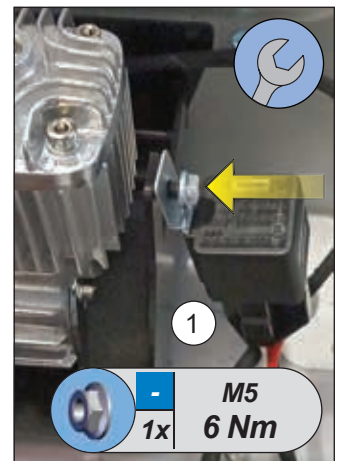
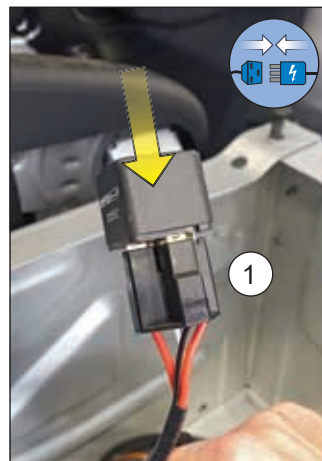
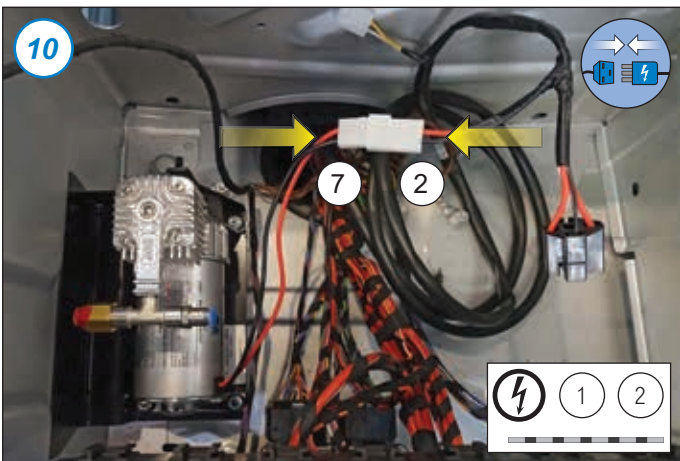
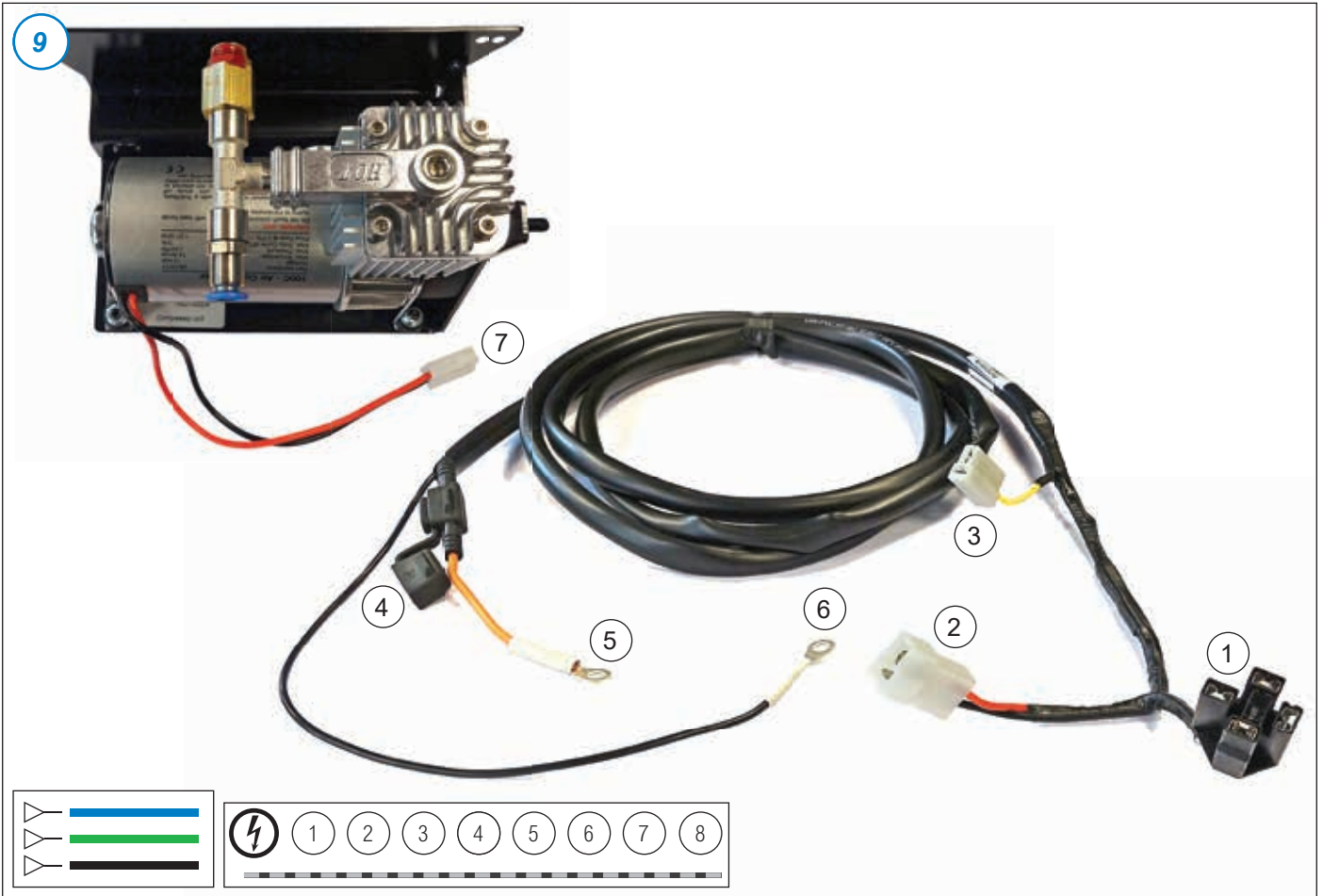

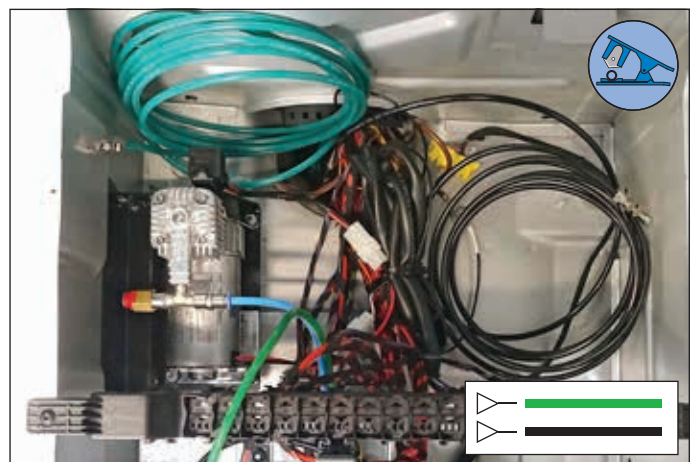
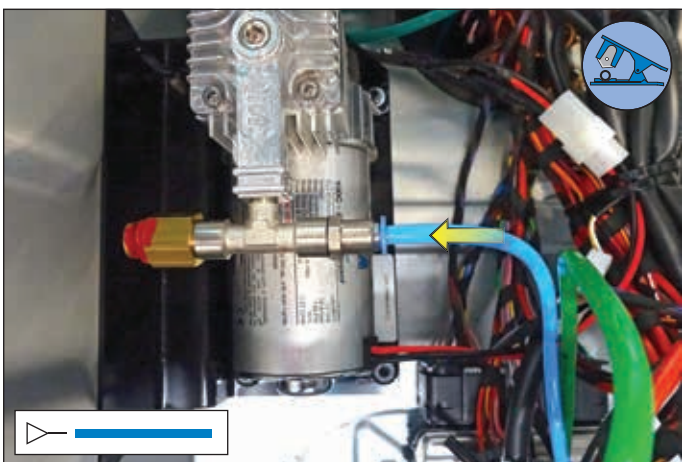
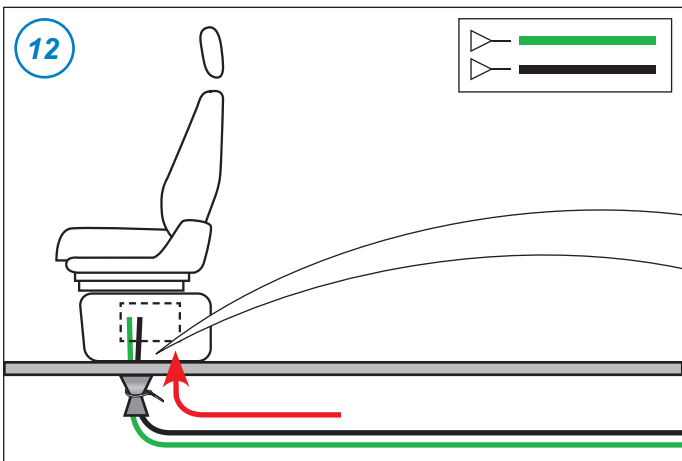
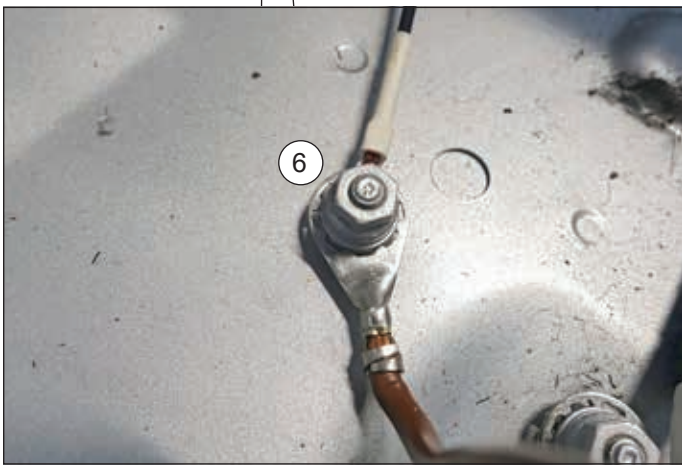
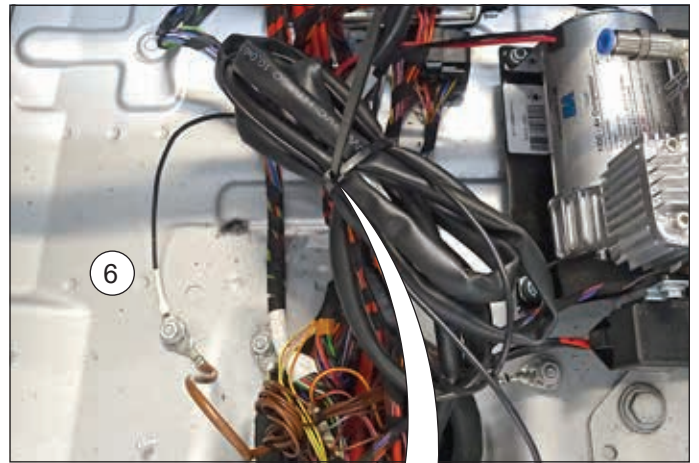
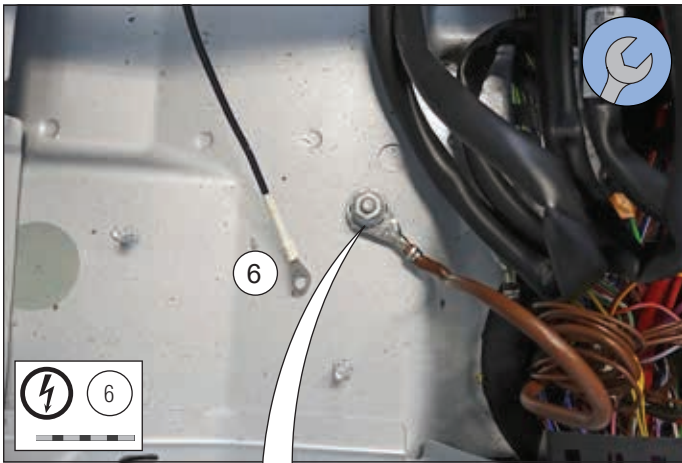

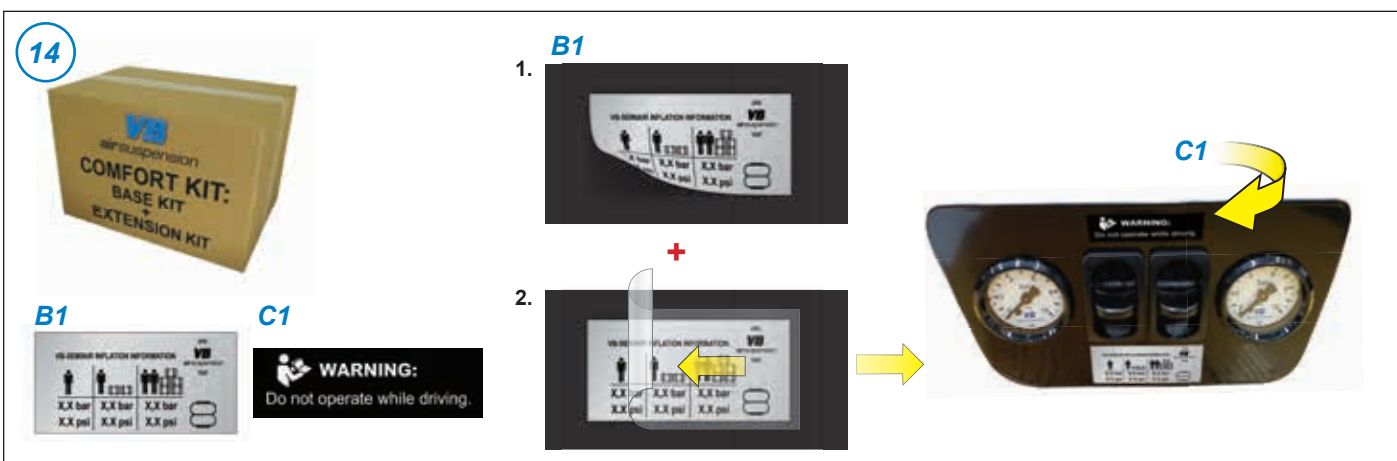
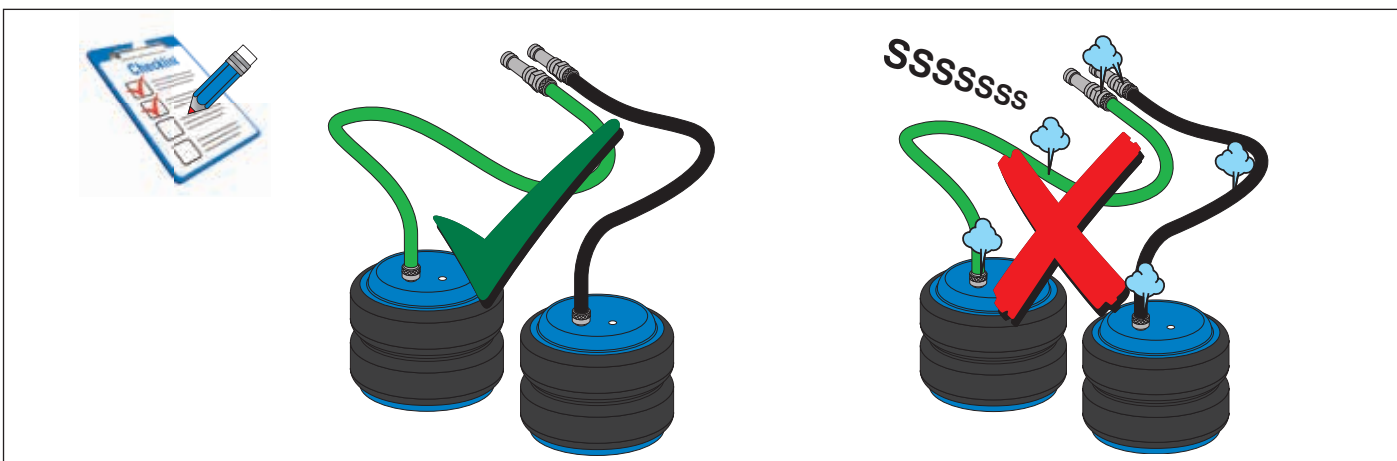
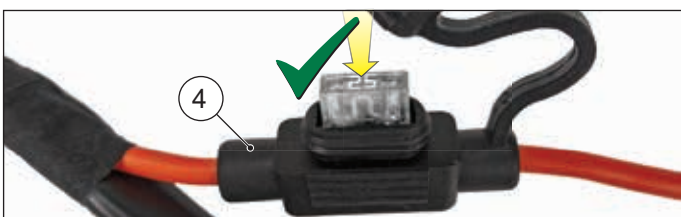
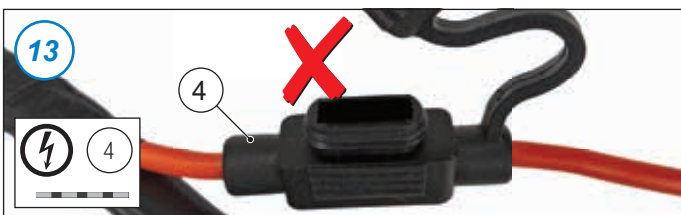
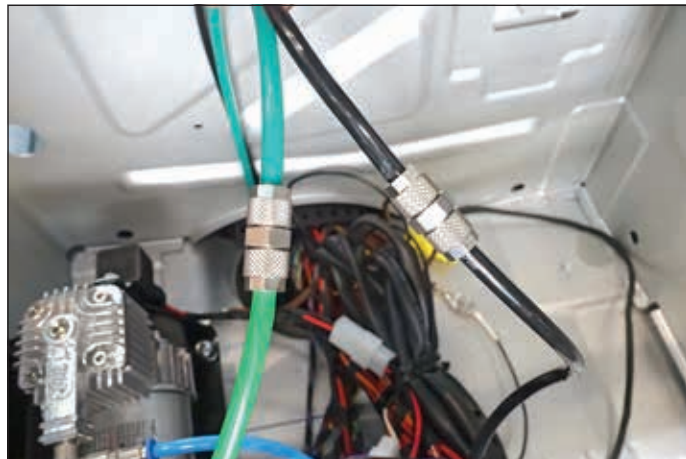
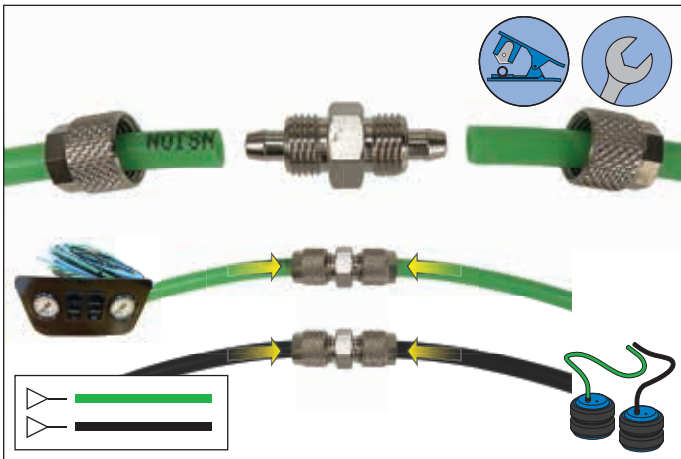

15

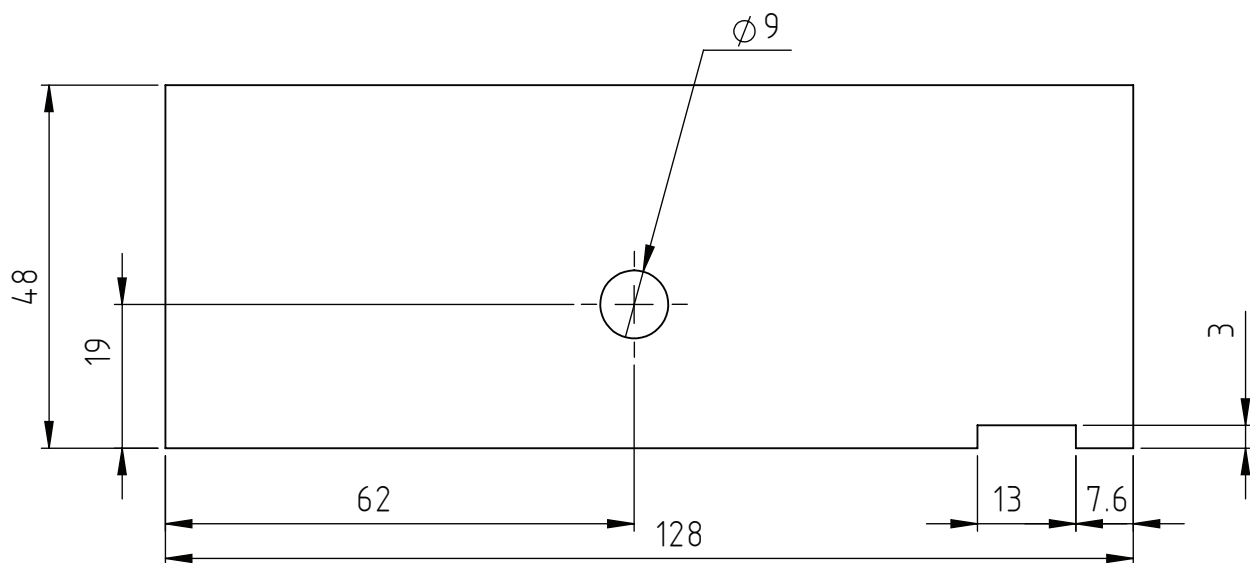
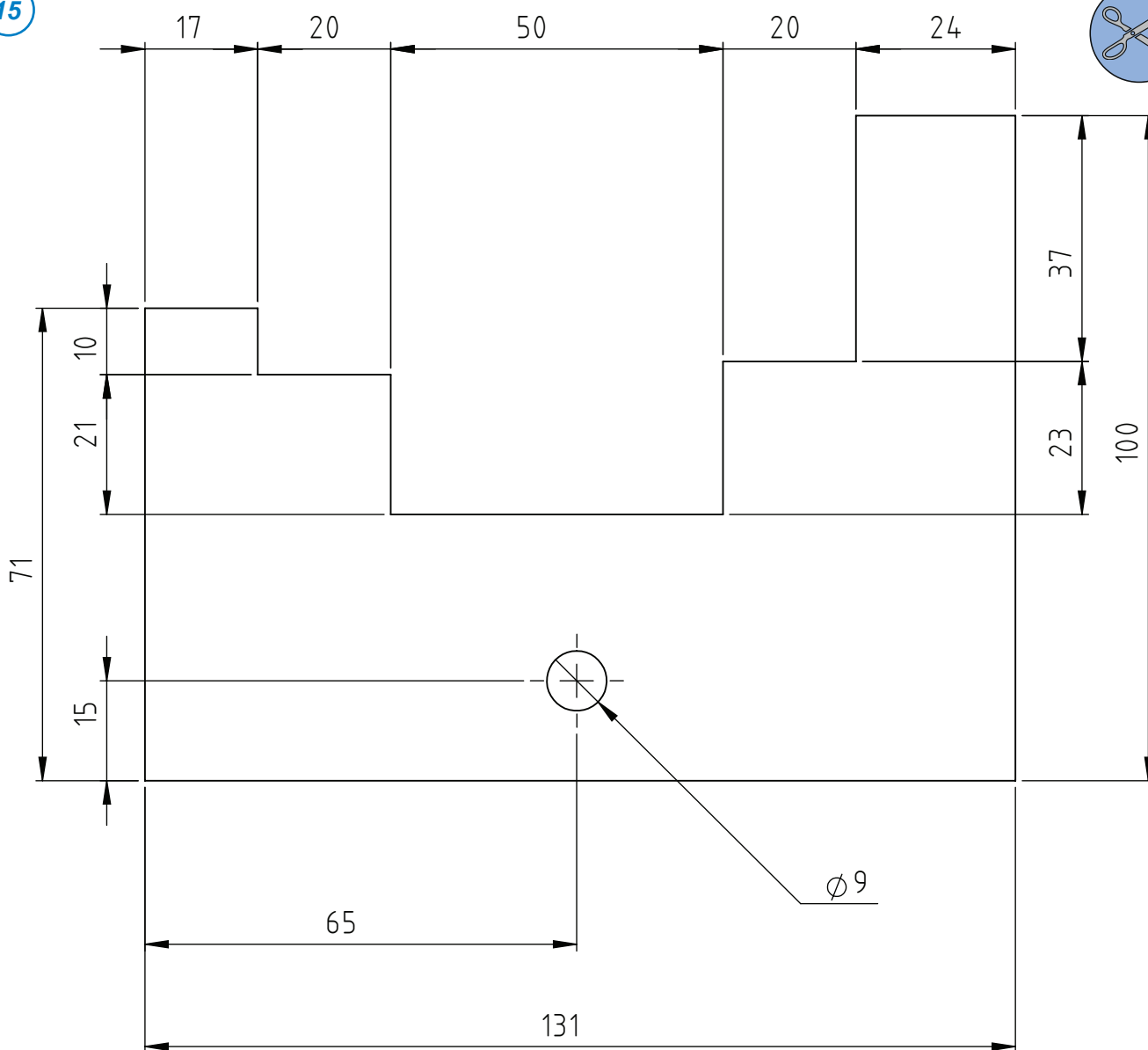
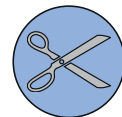

8. CHECKLIST

EN

Checklist



- Bolts tightened to correct torque.
- System checked for air tightness.
- Headlamp adjustment checked.
- If prescribed, have ADAS (Advanced Driver Assistance Systems) recalibrated.

OK

NL

Controlelijst



- Bouten aangedraaid tot het juiste aanhaalmoment.
- Systeem op luchtdichtheid gecontroleerd.
- Afstelling van de koplamp gecontroleerd.
- Indien voorgeschreven ADAS (Advanced Driver Assistance Systems) opnieuw laten kalibreren.

OK

DE

Checkliste



- Schrauben mit ordnungsgemäßem Drehmoment festgezogen.
- System auf Luftdichtigkeit geprüft.
- Scheinwerfereinstellung überprüft.
- Wenn vorgeschrieben ADAS (Advanced Driver Assistance Systems) neu kalibrieren lassen.

OK

FR

Liste de contrôle



- Boulons serrés au couple correct.
- Contrôle de l'étanchéité à l'air du système.
- Contrôle du réglage du phare.
- Si nécessaire, faire recalibrer le système avancé d'assistance au conducteur (ADAS).

OK

TR

Kontrol listesi



- Civatalar doğru tork ile sıkıldı ve işaretlendi.
- Sistem, hava sızdırmazlığı açısından kontrol edildi.
- Far ayarı kontrol edildi.
- Gerekirse ADAS'ı (Gelişmiş Sürücü Destek Sistemleri) yeniden kalibre ettirin.

OK

IT

Liste de contrôle



- Bulloni serrati alla coppia corretta
- Sistema controllato per la tenuta all'aria.
- Controllo regolazione fari.
- Se prescritto, avere ADAS (Sistemi avanzati di assistenza alla guida) ricalibrato.

OK



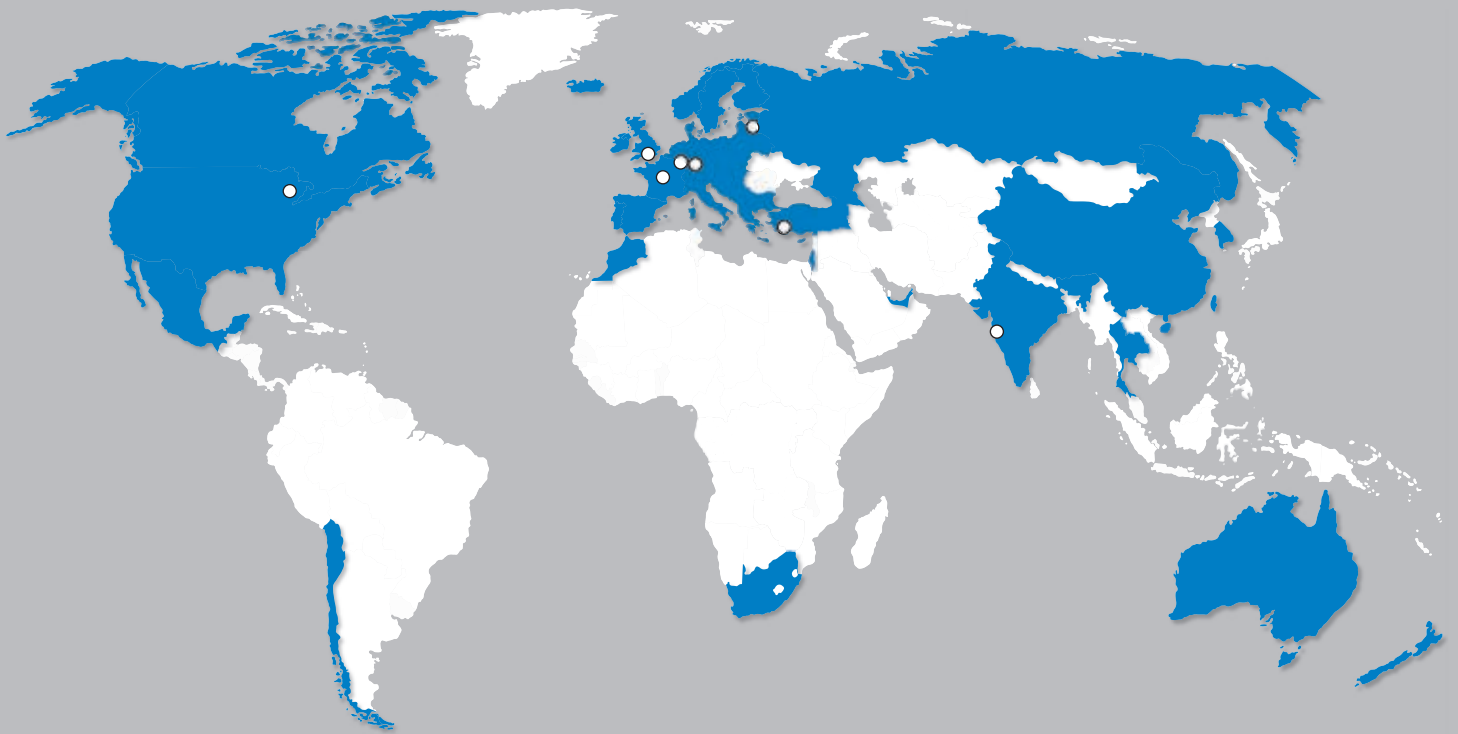

VB-AIRSUSPENSION,

INCREASED COMFORT, BETTER DRIVEABILITY, MORE SAFETY.

